

## CARD EDGE CONNECTORS

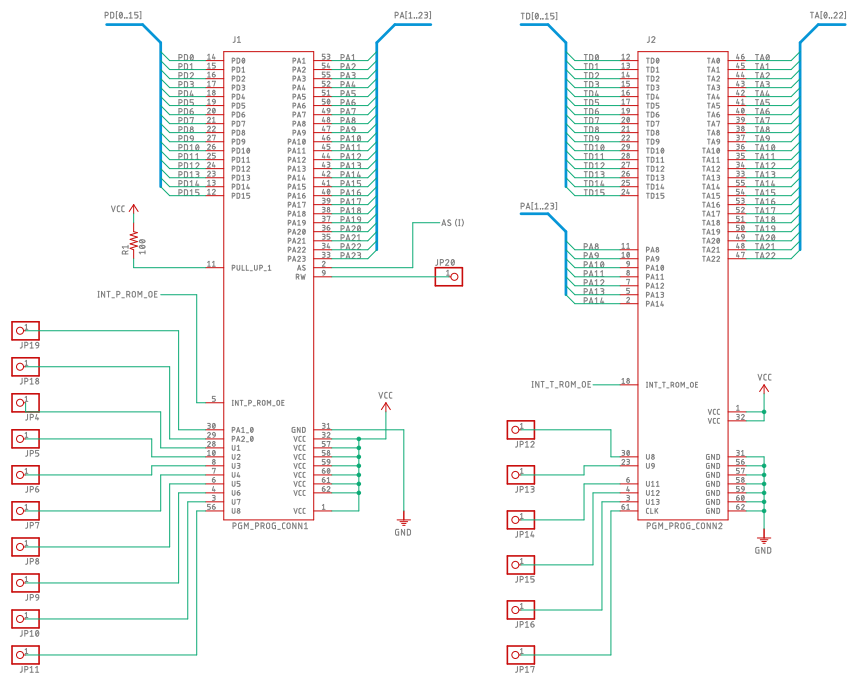

## P-ROM CONTROL LOGIC

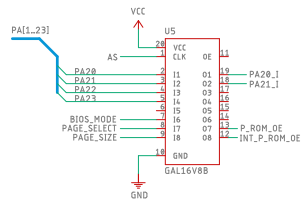

## P-ROM DATA BUS PULL-UPS

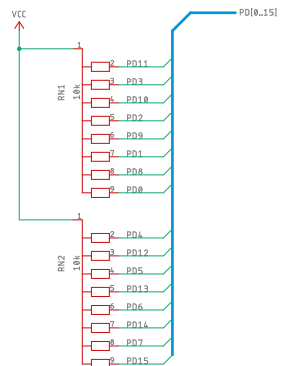

## P-ROM

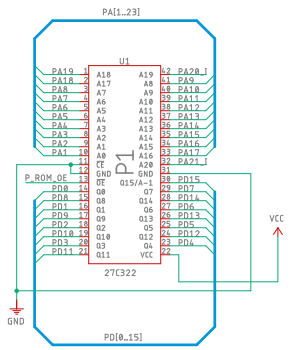

## POWER

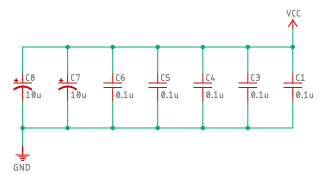

## JUMPERS

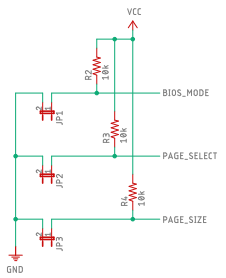

## T-ROMS

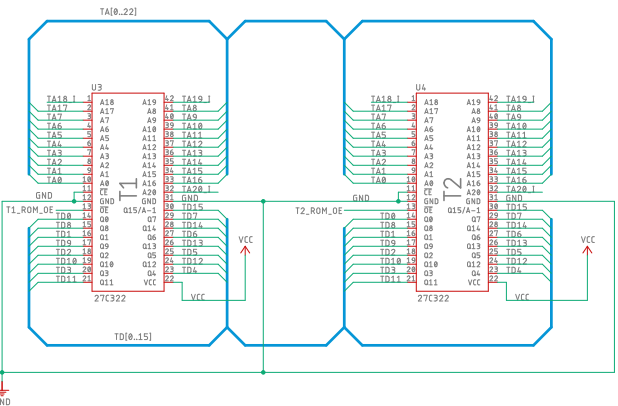

## T-ROM CONTROL LOGIC

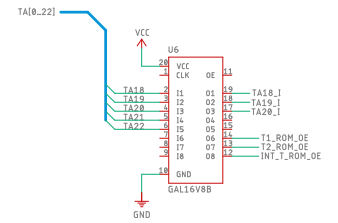

## BILL OF MATERIALS

QTY	LOCATION	VALUE	DESCRIPTION
3	U1, U3, U4	ST 27C322	32Mbit x 16-bit EPROM DIP42
2	RN1, RN2	10kΩ	BUSSED RESISOR ARRAY 9 PIN
3	R2, R3, R4	10kΩ 1/4W	RESISTOR
1	R1	100Ω 1/4W	RESISTOR
2	U5, U6	GAL16V8B	PROGRAMMABLE LOGIC
5	C1, C3, C4, C5, C6	0.1uF	CERAMIC CAPACITOR 5mm PIN SPACING
2	C7, C8	10uF	ELECTROLYTIC CAPACITOR 5mm DIA. x 2.5mm PIN SPACING
3	JP1, JP2, JP3	JUMPER	2-PIN HEADER 0.1" SPACING